

PHONE: 1-800-243-9577  
 WWW.CARBIDETOOL.COM  
 QUOTE@CARBIDETOOL.COM

# CARBIDE TOOL SERVICES, INC.

1020 LUND BLVD.  
 ANOKA, MN 55303

## SPINDLE SPEED INCREASER

Carbide Tool Services is Colibri's official certified North America Service Center.

We repair all brands of Colibri spindle speeders.



## INDEXABLE TOOL REPAIR



- Tool Holders
- Boring Bars
- End Mills
- Milling Cutters
- Drills
- Quick Change Tooling

## PREMIUM PNEUMATIC TOOL REPAIR



Condensation, water buildup, and rust can all affect the performance of your air tools. We can repair these tools for a fraction of the new tool cost!

## LIVE TOOL AND AGGREGATE HEAD REPAIR

Carbide Tool is here to help rebuild any brand of live tooling you have!

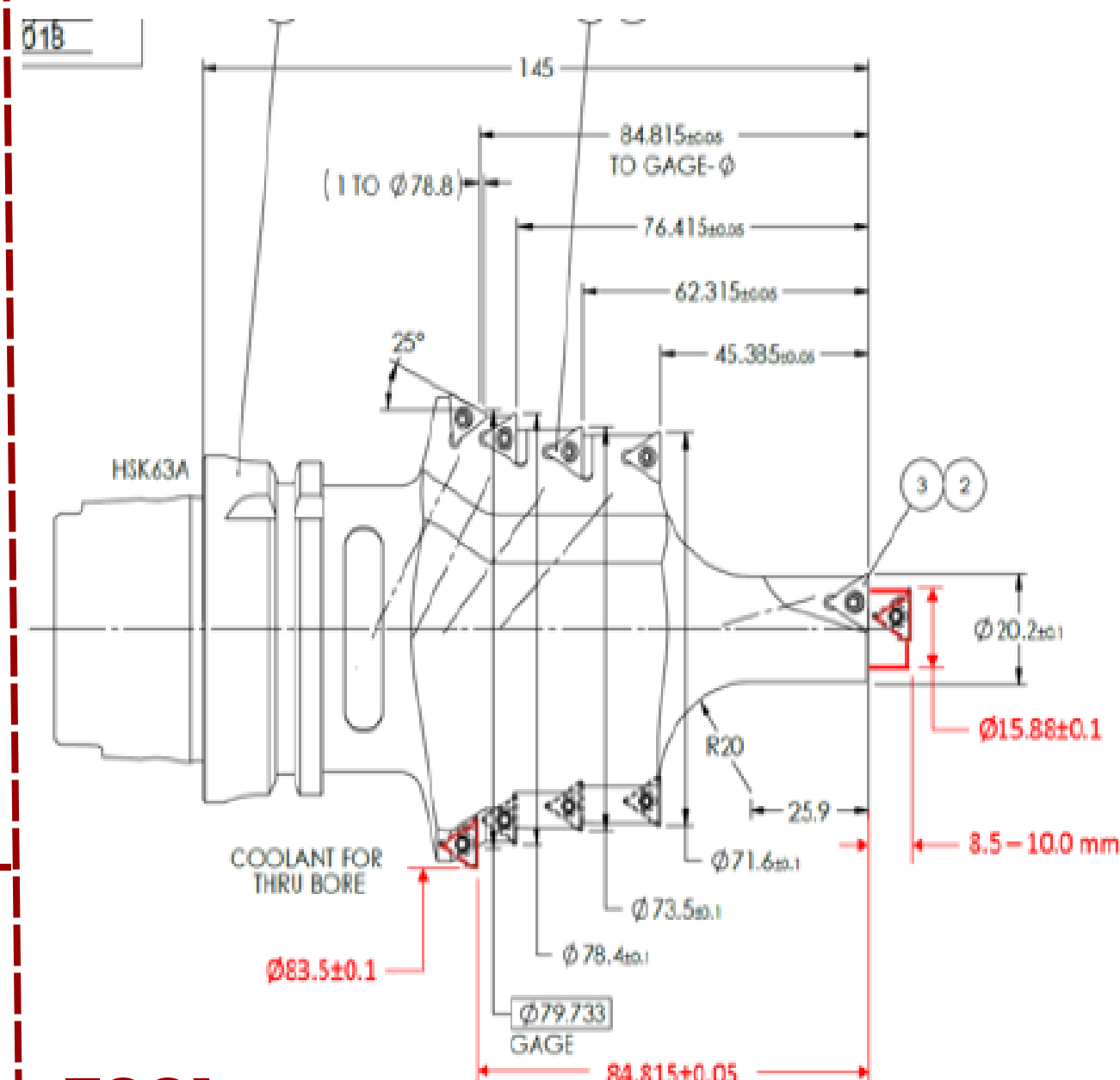
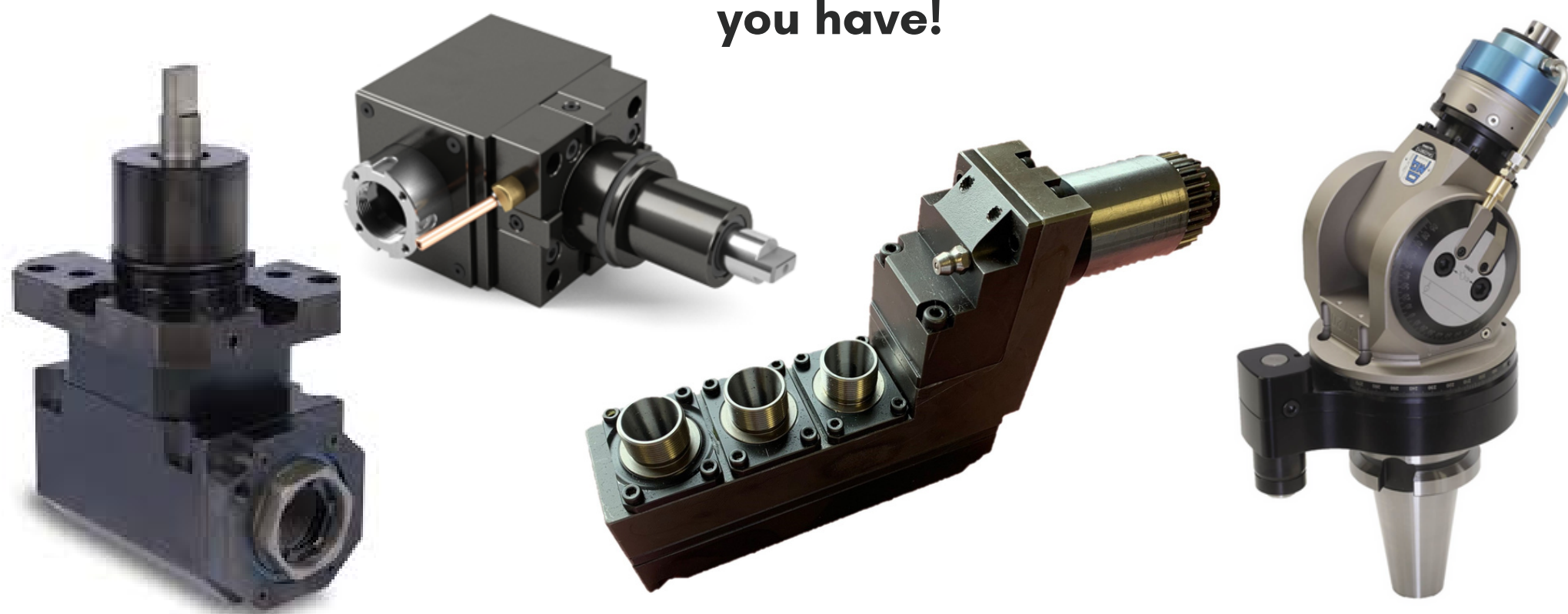

## NEW TOOL AND PRODUCT MANUFACTURING

We can build your indexable tool to print or sample.

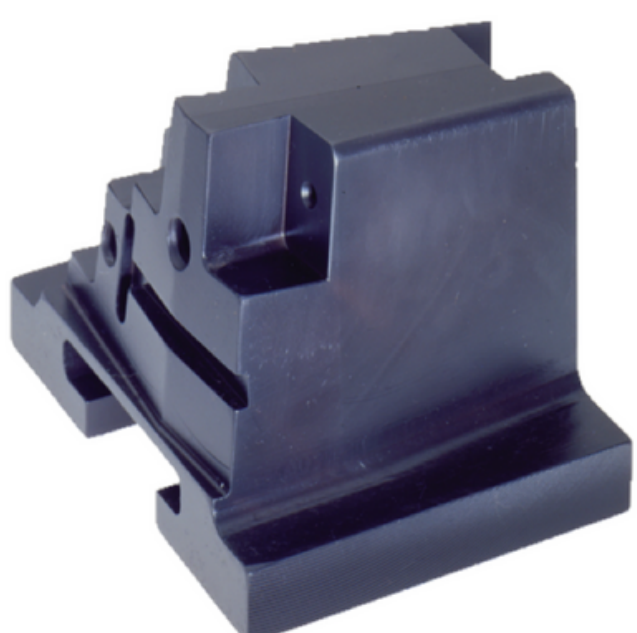

## TOOL MODIFICATIONS

